

S4962DM 1002 / 1010 / 1028 / 1036

BOILER CONTROL SYSTEMS

PRODUCT HANDBOOK

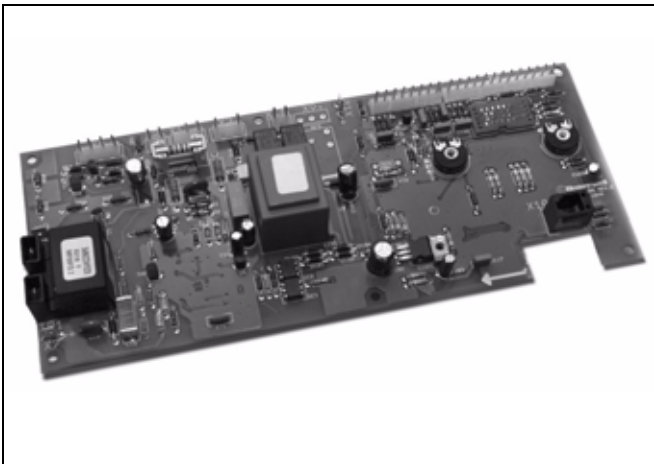

APPLICATION

The S4962 boiler controls have been specially developed for application in gas fired domestic appliances.

The S4962 boiler controls are used in conjunction with the VK41.. series modulating or non modulating gas controls (see Product Handbook EN2R-9025 and EN2R-9004) to provide both an optimised safety sub-system for programmed safe light-up and flame supervision of the main burner of the appliance and a boiler comfort control sub system for temperature, pump, and 3-way valve control

For a gas fired boiler moreover bi-directional open therm (OT) communication with a MMI enables comprehensive diagnostics and operation.

For glossary of terms, abbreviations and symbols see document EN2R-9039

Contents

General	Page
Description	2
Features	3
Technical	
Dimensional drawing S4962 boiler control	4
Specifications	5
Connection diagram	6
Timing diagram	7
General considerations	8
Electrical connections and wiring	9
Adjustments and final checkout	10
Various	
EMC guidelines	11
Quality assurance statement	12
Standards and approvals	12

DESCRIPTION

The S4962 boiler control operates in conjunction with a VK41.. modulating or non-modulating gas control.

The boiler control consists of an automatic ignition control and a comfort boiler control.

The features are listed below.

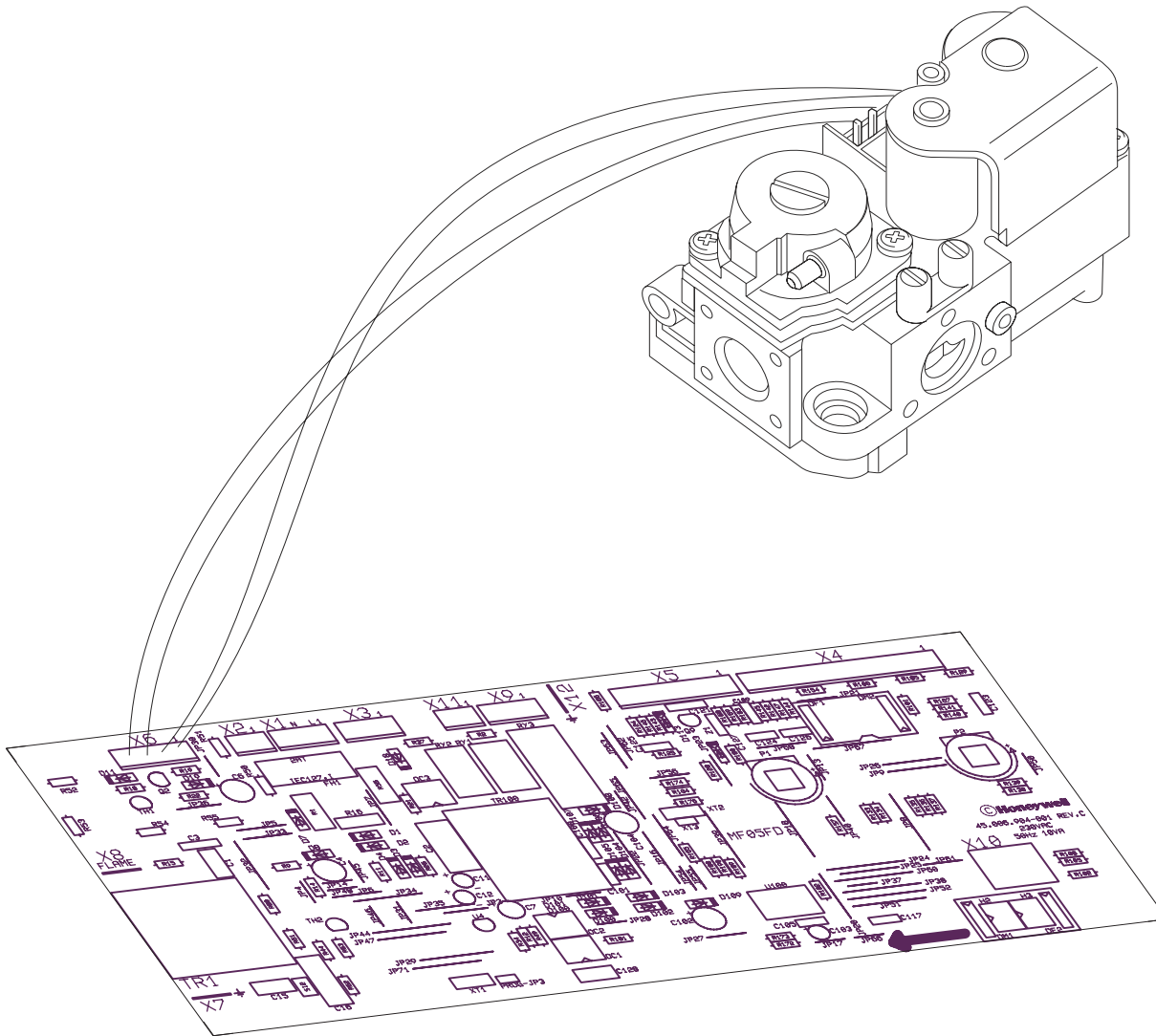

FEATURES

- Multi trial full sequence ignition control.
- Permanent operation in accordance with EN 298.
- Direct Burner operation.
- Integral ignition including emission filter.
- Phase insensitive flame detection.
- Lock-out at flame simulation.
- Restart after flame loss.
- AC fan on/off control
- Dynamic airflow check.
- Lock-out on no air.
- Automatic fan assisted/atmospheric recognition.
- Integral gas pressure modulation circuitry.
- Pump control.
- 3-way valve control.
- Multi temperature CH and DHW control with DHW priority setting.
- Flow sensor input.
- Contact switch high limit.
- Built in MMI enables comprehensive diagnostics and operation.
- Factory safety parameter settings.
- Installer and OEM comfort boiler control parameter settings.
- On board transformer and wiring center.
- Integral reset and alarm indicator.
- Electrical safety in accordance with EN 60730.

For detailed specification see honeywell document
45.006.942-001

DIMENSIONAL DRAWING S4962 BOILER CONTROL

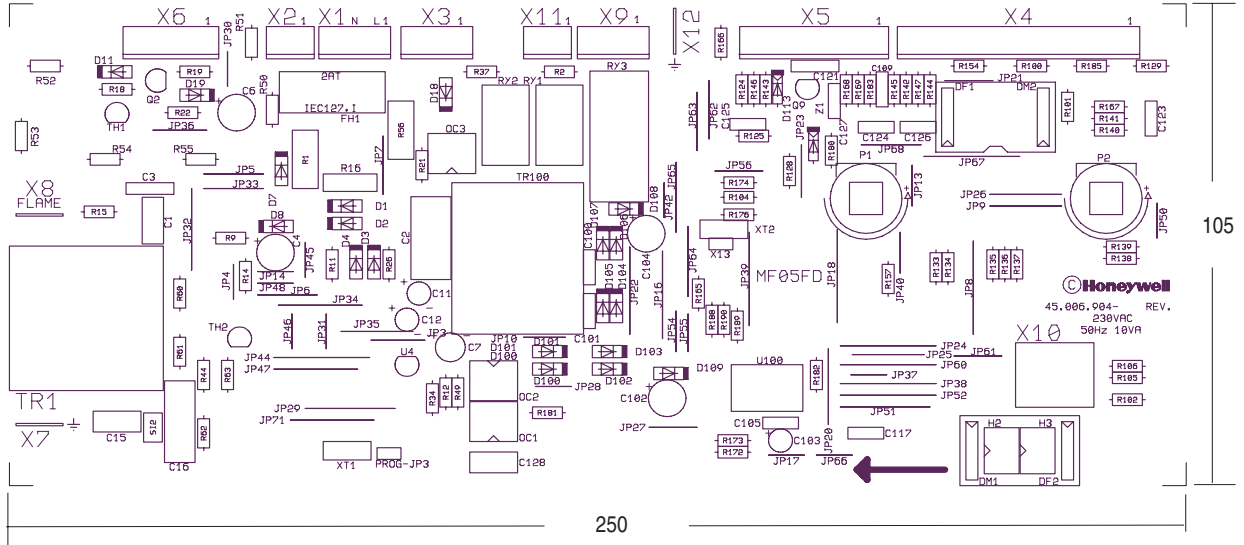

SPECIFICATIONS

Models

Basically there is one PCB for a number of applications. Depending on which components are mounted different applications can be covered.

Supply voltage

230 Vac, -15% +10%
50Hz ± 2Hz

Power consumption

8 VA

Humidity

90% RH max. at 40°C (non condensing)

Ambient temperature

- 20 ... 60°C

Electrical rating

Mains input:

230 Vac +10 / -15 %

fusing:

internal: 2 A slow maximum

Pump output:

230 Vac, 0.8 A max, cos φ q 0.6

AC fan output:

230 Vac, 0.8 A max, cos phi q 0.6

3 way valve or water filling valve output:

230 Vac, 0.8 mA max, cos phi q 0.6

Room thermostat input:

24 Vac, 10 mA or by communication, OT input.

Gas valve output:

230V_{vac}, 50mA

Air pressure switch input:

5 Vdc, 100 kOhm

High limit switch input:

5 Vdc, 100 kOhm

Water pressure sensor:

5 Vdc

Flow sensor input and output:

12 ± 4Vdc, 10 mA max supply open collector input

Alarm output:

via external communications

Sensors inputs 3:

10 kOhm NTC

Communication input and output:

input: logic "0" p 0.8 Vdc

logic "1" + 2 ... 24 Vdc (10 kOhm)

output: open collector 24 V and 10 mA max

Electrical PCB connectors

High voltage spark:

2.8 x 0.5 mm spade terminal

Flame sensing:

6.3 x 0.8 mm spade terminal

Mains connector:

Molex 5.08 mm standard (male)

Low voltage connectors:

Molex 3.96 mm (male)

Earth connector

6.3 x 0.8 mm spade terminal

Flame sensing

Factory parameter setting:

minimum flame current : 5 µA

Ignition

Spark voltage:

15 kV

Spark frequency:

15 Hz

Spark pulse energy:

5 µAs

Timing

Safety time (T_s):

5 s

Number of retrials:

3

Flame failure response time:

1 s

Stabilisation time:

Post ignition/stabilisation time:

Post purge time:

0 .. 55 s

Pump over run time:

6 min

Anti cycling time:

120 s

Communication

Bit rate:

2400 baud

Byte format:

1 start, 8 data, 1 stop,
no parity

Bit value "1":

low line level at connector

Bit value "0":

high line level at connector

Length flame sensing cable

0.5 m max.

Length spark cable

0.5 m max.

Length of wiring for external components

1 m max.

Spark frequency at 230 V line voltage

$0.7 f_{\text{spark}} \leq f_{\text{spark}} \leq 1.4 f_{\text{spark}}$

Spark energy

>0.6 * specified spark energy

Product life

500.000 cycles for safety and main valve operator of gas valve

250.000 cycles at rated loads

6.000 lock out operations with rated loads

CONNECTION DIAGRAM

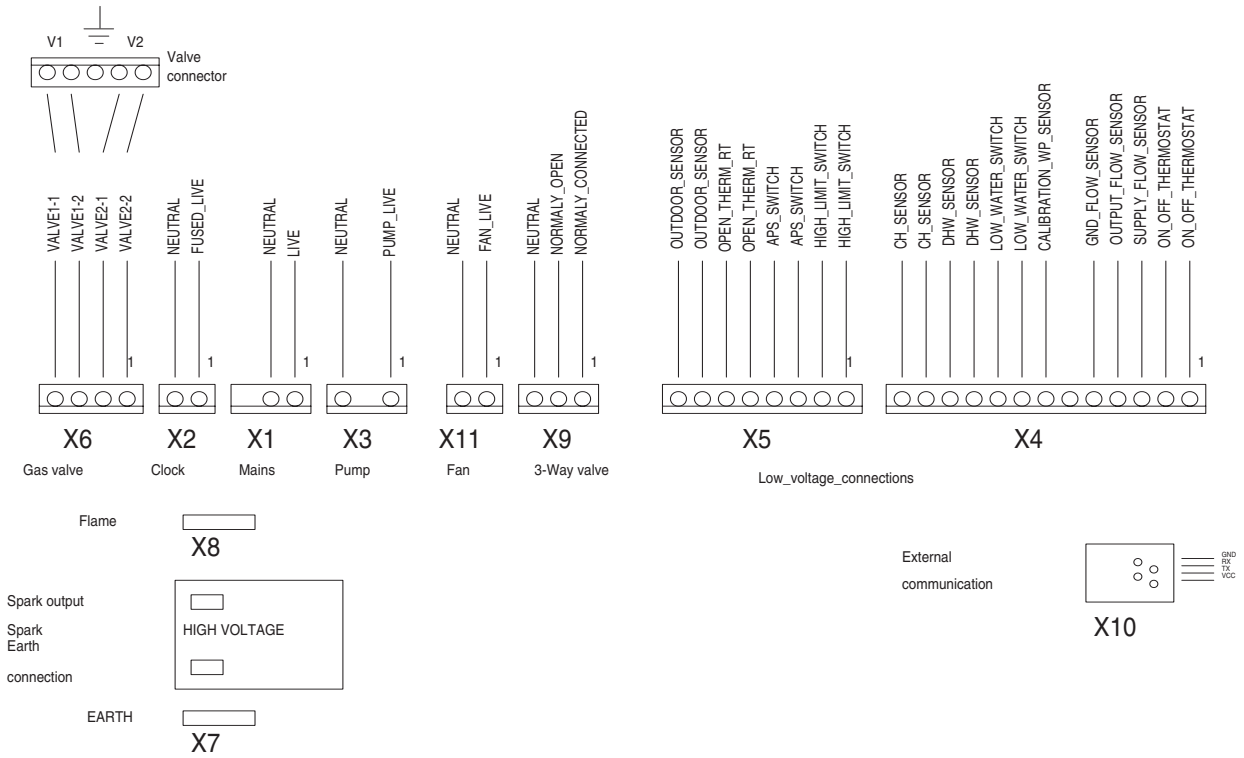

Fig. 1. Connection diagram S4962DM1002/1010/1028

TIMING DIAGRAM

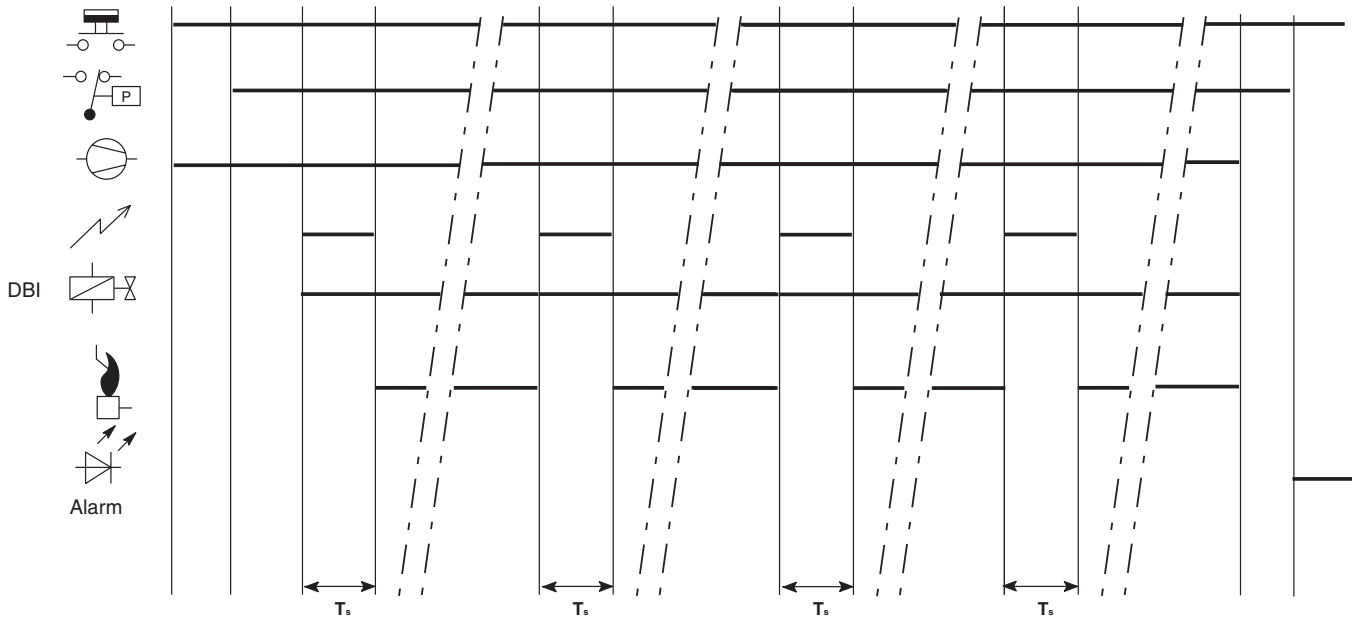

Fig. 2. General timing diagram S4962DM1002/1010/1028

GENERAL CONSIDERATIONS

To ensure reliable long term operation, mount the boiler control at a position in the appliance with a low ambient temperature and a low radiation.

High temperatures will affect product life.

NOTE 1.: When first starting the boiler control has a self check time of about 10 seconds.

NOTE 2.: Electrical rating of connected controls should be appropriate for the load that is switched by the boiler control.

NOTE 3.: Disconnect the boiler control from mains before performing a dielectric strength test.

NOTE 4.: The flame connection pin of all types is **NOT** protected against electrical shock.

NOTE 5.: An automatic return high limit thermostat can be used.

NOTE 6.: The modulation function of the S4962 boiler control units is checked during the start up safety check. As a result the gas technical safety of the appliance provided with a S4962 boiler control unit can rely on the proper functioning of the adjustable gas outlet pressure during ignition of this boiler control unit.

NOTE 7.: Remote reset function may only be used in applications where a maximum of five resets per 15 minutes is allowed.



WARNING

Honeywell is not responsible for damage and/or injury due to mis wiring.

After installation boiler control can become wet due to condensation. **Do not connect humidified device to mains.**

ELECTRICAL CONNECTIONS AND WIRING

WARNING

Take care that installer is a trained experienced service person.

Disconnect power supply to prevent electrical shock and/or equipment damage.

IMPORTANT

Wiring must be in accordance with local regulations.

The appliance manufacturer's instructions should always be followed when provided. If such instructions are not provided see the connection diagrams for typical systems.

Before installing or replacing any control check that type number is correct for the application.

Ensure combustion chamber is free of gas before start up.

Conduct a thorough check out when installation is completed.

CAUTION

Do not connect the boiler control to power supply when it is not connected to the gas control.

Wiring

- Use leadwire which can withstand at least 105°C ambient.
- Use leadwire which is proven against moisture.
- Wiring between boiler control and spark sensing probe should have good quality insulation, suitable for the temperatures encountered.

Fusing

The boiler control has internally fusing.

Spark gap

Max. allowable spark gap 3.5 mm

ADJUSTMENTS AND FINAL CHECKOUT



WARNING

Adjustments must be made by qualified persons only. If the appliance manufacturer supplies checkout and/ or service and maintenance instructions carefully follow them. If these instructions are not provided then use the

Checking flame current

- The minimum value should be 5 μ A.
- To check flame current connect a DC micro-Ampèremeter between flame sensing wire and flame sensing rod.
- Meter connections polluted with e.g. alkaline substances lying close to earth can cause flame current simulation. Make sure no false flame current can flow from meter connections to earth.
- If flame current is insufficient check that the flame sensing rod is fully enveloped by the flame and that the burner and the boiler control are reliable grounded.

Final checkout

After installation and any adjustment start the appliance and observe a complete cycle to ensure that all burner components function correctly.

Maintenance and service

Under normal circumstances no maintenance or service is required.

EMC GUIDELINES

The ignition cable has to be determined for lowest emission.

Do not lead ignition cable close to other cabling.

To suppress Radio Frequency Interference (RFI) the boiler control including spark igniter cabling should be mounted in sufficient shielded environment.

QUALITY ASSURANCE STATEMENT

Products are manufactured under an ISO 9001 (1994) based and certified Quality System.

The quality system is described in the Honeywell Combustion Controls Center Quality Assurance Programme and its related operational procedures and instructions.

The quality system is approved by Gastec against certificate number 9.302/2.

The quality organisation is responsible for defining, maintaining, improving and verification of the quality systems in the field of design, production process and field quality service.

Assembly processes are guided by work instructions. Patrol inspections form part of the assembly processes.

Assembly inspection is performed by employees of the quality control department, using their own authorised equipment.

All inspections (incoming and assembly) are performed by trained personnel and according to inspection procedures.

STANDARDS AND APPROVALS

Standards

The S4962 has been designed to meet the European Standards:

- EN 298: Automatic gas burner control systems.
- EN 60730-1: Automatic electric controls for household and similar use.

Regarding electric safety, the S4962 can be used in appliances according to European Standard for household electrical requirements EN 60335 series

S4962 systems function in accordance with EN298.

S4962DM1002/1010/1028 code F/M/C/L/X/K

Approvals

The boiler control conforms with the following EC - Directives:

- Gas Appliance Directive (90/396/EEC)
- Low Voltage Directive (73/23/EEC)
- Electro Magnetic Compatibility Directive (89/336/EEC)*

* Conformity with Electro Magnetic Compatibility Directive regarding emission for non industrial appliances can be assumed for all selected Ordering .Specification (O.S.) numbers. However conformity can only be declared as part of the appliance.

Regarding immunity, all controls comply with the levels for non industrial appliances.

Honeywell

**Home and Building Control
Combustion Control Center Europe**