

V5475 NON ELECTRIC VALVE

PRODUCTION HANDBOOK

APPLICATION

The V5475 is a non-electric multifunctional combination gas control with mechanical modulation and on-off thermostat for temperature regulation of gas fired heating appliances.

The V5475 provides together with a Honeywell pilot burner and thermocouple fully automatic control of domestic space heaters, water heaters and catering equipment.

The V5475 is suitable for all gases and provides modern design and easy single knob operation.

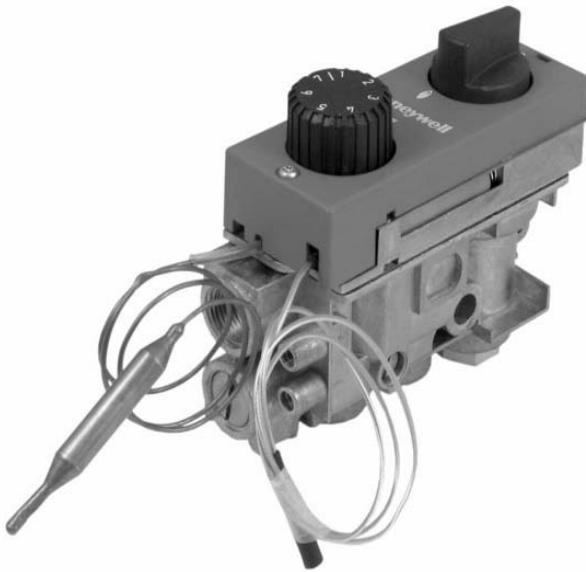

Contents

General	Page
Description	2
Features	3
Technical	
Specifications	4
Performance characteristics	5
Capacity curve	6
Temperature curve	7
Dimensional drawing	8
Installation	9
Operation	10
Adjustments and final checkout	11
Trouble shooting	12
Working principles	13
Various	
Ordering information	14
Replacement parts and accessories	16

DESCRIPTION

The V5475 combination gas control performs all the functions required to safely regulate gas flow to the pilot burner and the main burner of gas fired heating appliances.

It optimises application possibilities with a standard valve construction providing inlet and outlet connections accessible from bottom and side.

The pressure regulator or throttle and pilot flame adjustments are accessible from the top.

It includes an adjustable minimum flow orifice.

The pilotstat is designed in an easy to use ergonomic single hand operation including an integrated piezo igniter. This pilot safety system contains a built in safe lighting latch, which makes it impossible to re-establish main burner gas flow between the time the pilot gas is manually turned off and the time the thermocouple has cooled sufficiently to drop out the reset mechanism. The pilotstat construction allows easy night set back, without changing the temperature setting.

The adjustable pressure regulator provides a large outlet pressure adjustment range. This pressure regulator can be turned into a blocked position for LPG applications.

The temperature can be controlled by a separate knob with clear indication. The thermostat provides snap action for on-off and modulating gas control. The minimum fire rate will be set by an adjustable orifice.

At the inlet a screen provides protection against dirt entering the gas control.

The pilotstat unit contains a filter for the pilot gas and an adjustable pilot flame.

The V5475 combination gas control is rated for gas families MFD Group A (G 110), MFD Group B (G 120), Natural H (G 20), Natural L (G 25) and LP (G 30).

All measurements are carried out under standard conditions, unless otherwise is indicated.

Standard conditions

- P_{inlet} 25 mbar nominal pressure, dry air of 20°C
- $T_{ambient}$ 20°C
- Flow indication in m^3/h
- Recording of outlet pressure with a transducer connected to a $3/8''$ pipe with a length of 10 times the diameter with a short hose at 5 times the diameter.
- Attenuation X-Y recorder switched on zero.
- Upright position, i.e. the position when the knob is on top.

FEATURES

- Inlet and outlet connections from side and/or bottom.
- Compact design and modern styling.
- Capacity to cover manufactured gas, natural gas and LPG applications with only one gas control.
- Inlet and outlet pressure taps.
- 100% safety shut off and safe lighting pilot system.
- Latching device "interlock", eliminates involuntary re-ignition of the main burner.
- Incorporated pilot filter and adjusting screw for the pilot burner gas supply.
- Single knob for manual pilot and on/off operation and integrated piezo igniter.
- Adjustable pressure regulator provides constant outlet pressure.
- Single function temperature knob with integrated thermostat providing snap action (on-off) and modulation control from maximum to minimum gas flow rate.
- Adjustable minimum flow rate orifice.
- Environmental friendly liquid filling of temperature sensor.
- Wide ambient temperature range starting from 0°C and up to 80°C.
- Mounting holes at the bottom and at the side for rigid attachment to the appliance.
- compression fitting for pilot gas connection 4 or 6 mm
- ignition cable

SPECIFICATIONS

Model

V5475: Non electric valve with modulating on/off thermostat.

Suffix G: for boilers with regulator and modulation

Pressure regulator

Class C in accordance with EN 88

Dimensions

See page 8 and 9

Weight

0.45 kg

Pipe connection

- $\frac{3}{8}$ " parallel pipe thread in accordance with ISO 7-1 for mounting 12 mm outer diameter tubing.
- Inlet and outlet at front side
- Inlet and outlet at bottom
- Inlet at front side and outlet at bottom
- Inlet at bottom and outlet at front side

Pipe connections are designed to meet the bending stress of group 2 according EN 161.

Pilot gas connection

M10 x 1 for 4 or 6 mm outer diameter tubing

Thermocouple connection

M10 x 1

Ambient temperature

0 ... 80°C

Capacity (see also capacity curve page 6)

1.2 m³/h air at $\Delta p = 2.5$ mbar (inlet at bottom side)

1.15 m³/h air at $\Delta p = 2.5$ mbar (inlet at front side)

Minimum flowrate

$Q_{min.} \leq 30 \% Q_{max.}$

Pilot gas flow

Adjustable between 0.09 m³/h and 0.003 m³/h at $\Delta p = 9$ mbar

Pressure regulator range

2.5 ... 20 mbar

Pressure regulator

Class C in accordance with EN88

Maximum Inlet pressure

50 mbar

Mounting

At the bottom and at the side of the valve there is a mounting support for an M5 fixing screw.

Pressure tap

Inlet and outlet pressure tap with 9 mm diameter.

Temperature sensor

for details see dimensional drawing on page 8

Temp. range (°C)	Max. temp. capillary (°C)	L1 : Bulb length (mm)	L2: Bulb contact length (mm)	L3 : Capillary length (mm)	D: Bulb diameter (mm)
40 ... 90	110	70	37	350	8

PERFORMANCE CHARACTERISTICS

Maximum allowable leakage

Each space heater control has been factory tested to meet the following leakage requirements.

Outer wall:

60 cm³ /h at 150 mbar.

Safety valve:

20 cm³ /h at 6 mbar and 50 mbar

Pilot gas position:

5000 cm³ /h at 50 mbar.

Disc valve in pilot gas position:

40 cm³ /h at 6 mbar and 150 mbar *

Disc valve in main gas position:

40 cm³ /h at 6 mbar and 150 mbar *

*) 1000 cm³ after 5 K cycles

Main valve:

60 cm³ /h at 6 mbar and 150 mbar

(by turning the temperature knob, the opening point will be searched. With constant temperature of the bulb, the knob will be turned 5 degrees back before this point. Bulb should be in mid range temperature)

Pilot flow

Pilot flow capacity is adjustable between 0.09 and 0.003 m³/h at a pressure drop of $\Delta p = 9$ mbar.

Power unit

Max. hold in current: ≤ 220 mA

Drop out current: 60 ... 230 mA

Outlet pressure range capability

Manufactured/natural gas spring: range 2.5 ... 18 mbar.

LPG application, blocked function up to 50 mbar when screw is bottomed.

Temperature range of thermostat

40 ... 90°C

Maximum overload

T = 110°C

Piezo igniter

Ignition probability: 95% when using a 35 pF capacitor and a Honeywell pilot burner.

Accuracy of pressure setting of regulator versions

6% of the setpoint value or 1.0 mbar, whichever is the greatest.

Repeatability of pressure setting of regulator versions

± 0.3 mbar or $\pm 3\%$ of the setpoint value, whichever is the greatest.

Design life

Thermostat

Setpoint from limit point to limit point: 10.000 cycles.

Snap action switch with 50 mbar air volume flow: 50.000 cycles.

Proportional range: 250.000 cycles

Operation cycle (Off - Power unit pull in - Igniter activated - Stand By - On - Stand By - Off - Power unit drop out):

7.000 cycles at 20°C

2.000 cycles at 80°C

1.000 cycles at 0°C

Piezo igniter

10.000 cycles

CAPACITY CURVE

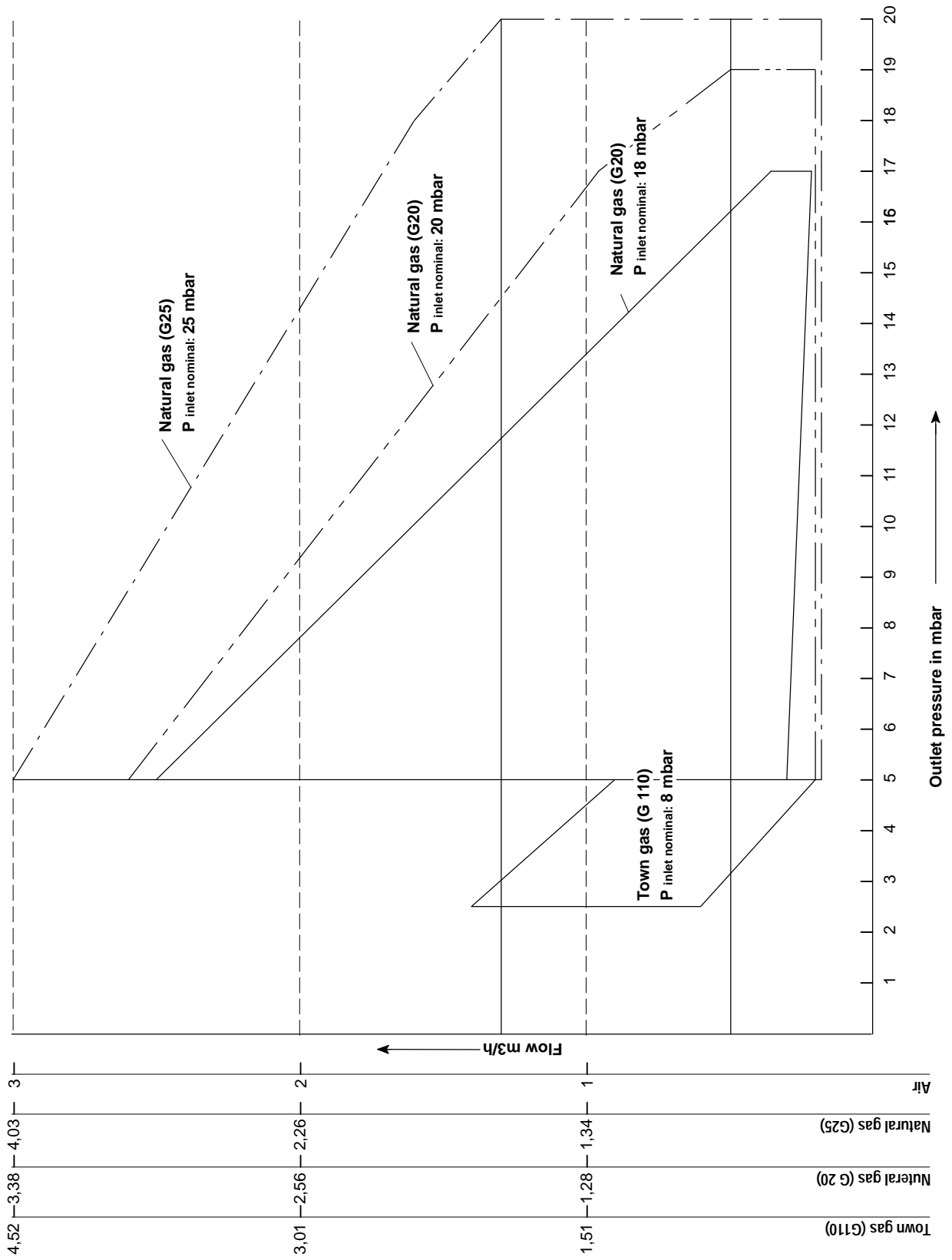

TEMPERATURE CURVE

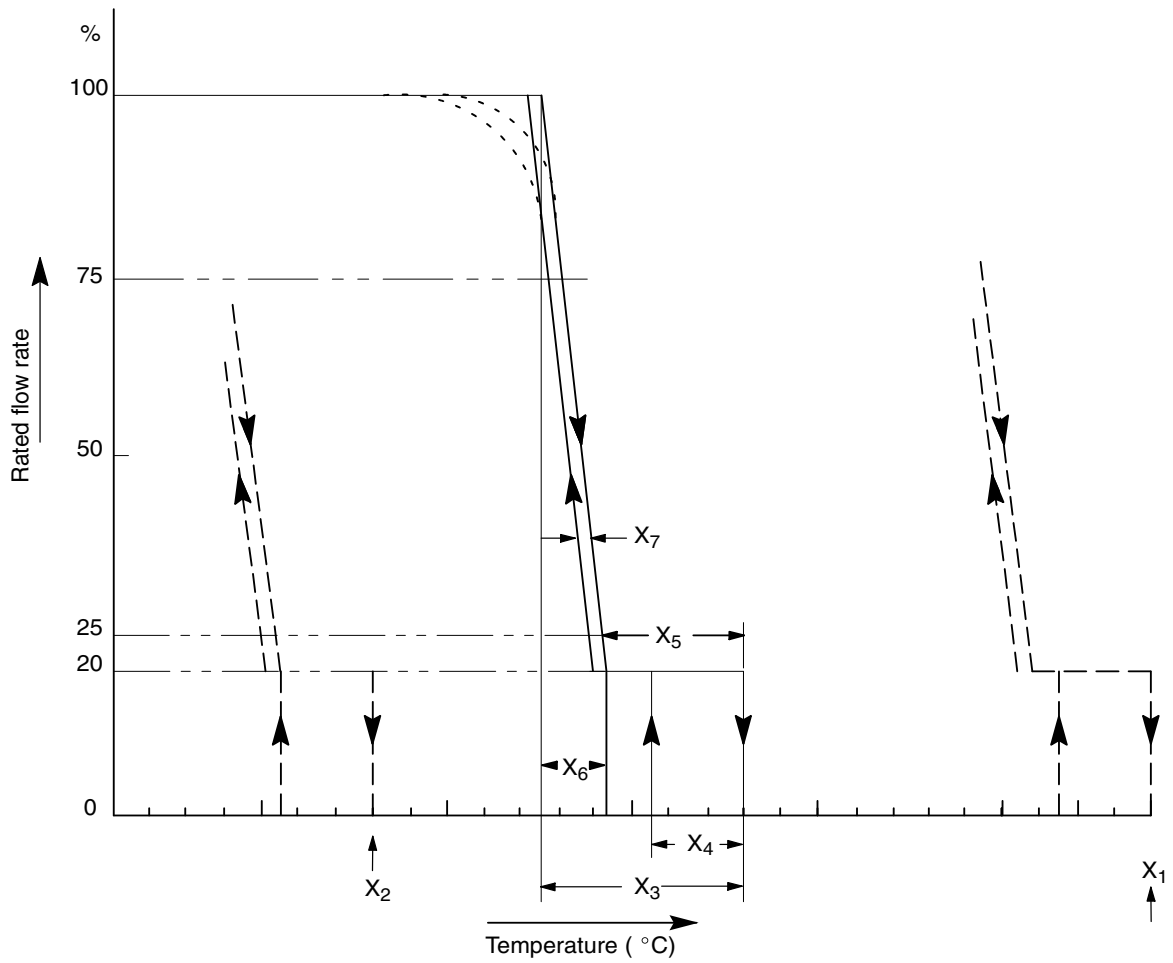

	Temperature range
	40 ... 90°C
X ₁ : Maximum setpoint knob position 7	90°C ⁺⁰ / ₋₅ K
X ₂ : Minimum setpoint knob position 1	40°C ⁺⁵ / ₋₁₀ K
X ₃ : Total differential	< 17 K
X ₄ : Snap on action differential	5 ⁺⁴ / _{-2.5} K
X ₅ : Maximum length bypass flow	< 11 K
X ₆ : Proportional band range	4 ^{+/-} 2.5 K
X ₇ : Hysteresis main flow	< 5 K
Influence ambient temperature	1 : 2.2
Maximum temperature sensing element	110°C

DIMENSIONAL DRAWING

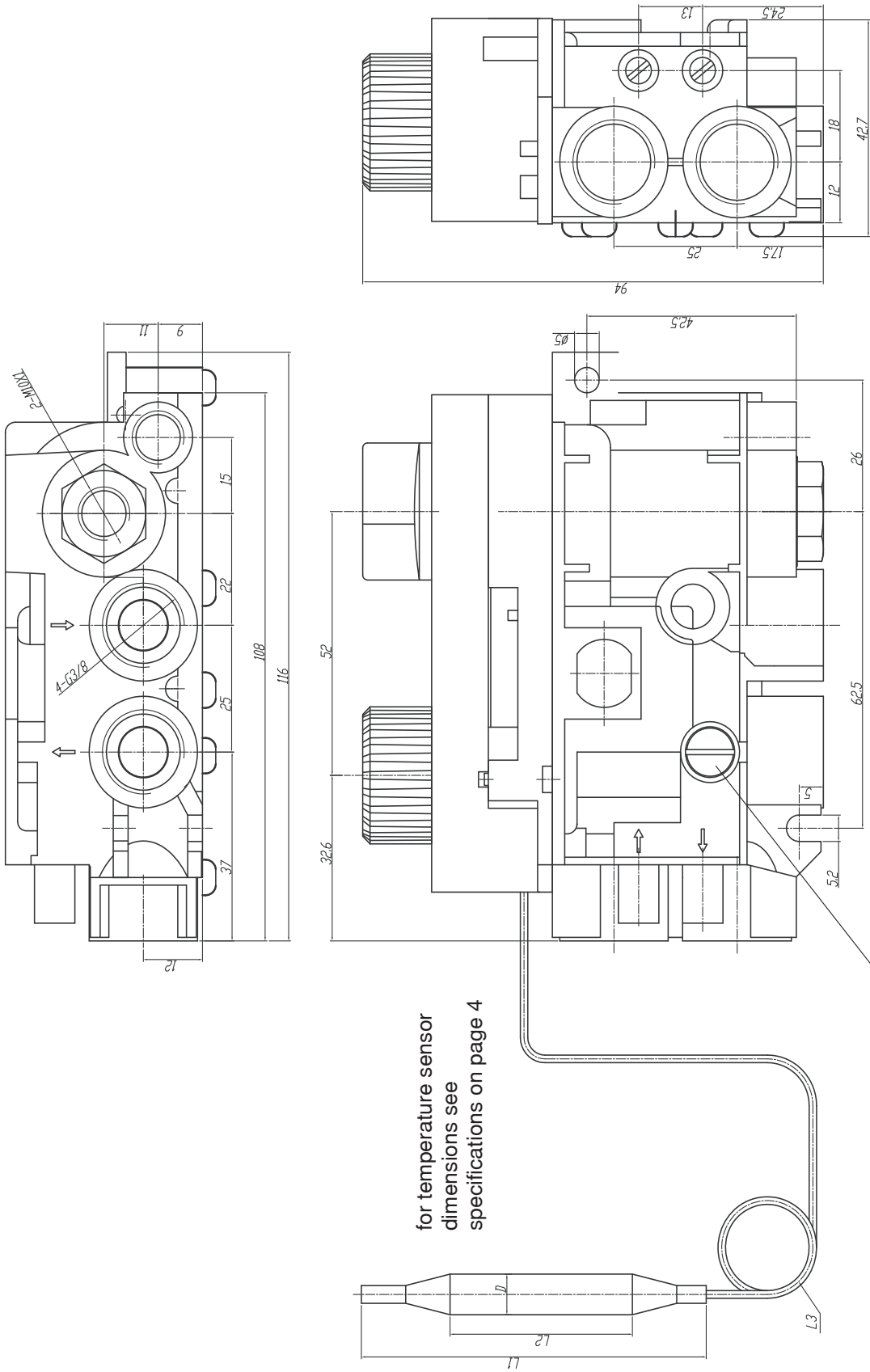

for temperature sensor
dimensions see
specifications on page 4

adjustment screw minimum bypass flow

INSTALLATION

IMPORTANT

Take care that installer is a trained experienced service person.

Turn off gas supply before starting installation.

Mounting position

The non electric valve can be mounted 0 to 90 degrees in any direction from the upright position i.e. from the position when the knobs are on top.

Main gas connection

- Take care that no dirt can enter the valve during handling.
- Square off end of tubing and remove burrs.
- Slip gland and ferrule over tubing.
- Insert tubing into the inlet/outlet until it bottoms, slide ferrule and gland into place and turn finger tight. **Do not use jointing compound.**
- Use a wrench to tighten gland about one turn beyond finger tight.

Pilot gas connection

- Square off the end of tubing and remove burrs.
- Slip compression fitting over tubing. Insert tubing into pilot outlet connection until it bottoms, slide fitting into place and turn finger tight. **Do not use jointing compound.**
- Use a wrench to tighten fitting about 1¹/₂ turn beyond finger tight to shear of the olive.
- Connect other end of tubing to pilot burner according to the manufacturer's instructions.



CAUTION

Do not bend tubing at space heater gas control after compression fitting has been tightened, as this may result in gas leakage at the connection.

Thermocouple connection

The non electric valve has an electrical thermocouple connection and must therefore be kept clean and dry; thread compound should never be applied to it. Tighten only 1¹/₄ turn beyond finger tight in order to give good electrical connection. When routing the thermocouple tubing, do not bend it too sharply (minimum radius 2.5 mm).

Mounting of interruptor (optional)

- Screw interruptor light finger tight into the power unit.
- Place the AMP tag into the plastic guide of the interruptor.
- Screw thermocouple into the interruptor and tighten 1¹/₄ turn with a wrench.

Perform gas leak test



WARNING

FIRE OR EXPLOSION HAZARD CAN CAUSE PROPERTY DAMAGE, SEVERE INJURY OR DEATH

Check for gas leaks with a rich soap and water solution any time work is done on a gas control.

Gas leak test

- Paint all pipe connections upstream of the gas control with with a rich soap and water solution. Bubbles indicate a gas leak.
- If a gas leak is detected, tighten the pipe connection.
- Stand clear while lighting the main burner to prevent injury caused from hidden gas leaks, which could cause flashback in the appliance vestibule. Light the main burner.
- With the main burner in operation, paint all pipe joints (including adapters) and gas control inlet and outlet with with a rich soap and water solution or an approved leak detection fluid.
- If another gas leak is detected, tighten adapter screws, joints and pipe connections.
- Replace the part if gas leak can not be stopped.



CAUTION

Keep soap and water solution away from electrical connections.

Location of the bulb

The temperature sensing element should be placed in a location representative of temperature to be controlled.

OPERATION

General

The operation of the pilot safety system is accomplished by manipulation of a knob, corresponding with the programming symbols that indicate lighting and shut off.

Lighting procedure

- Turn the knob towards ignition position until a stop limit is reached, and press it down.
- Wait 5 seconds.
- Turn the knob further from the pressed position until it reaches the STAND-BY position.
- Wait 10 seconds, after the pilot burner has been lit.
- Release knob and turn to ON position.
- Wait at least one minute before another attempt to light the pilot burner is made, if pilot flame is not established.

Shut off procedure

- Turn the knob to the STAND-BY position.
- Press the knob slightly to get it out of the STAND-BY position slot and turn it to the OFF position.
- After about one minute (drop-out time of thermocouple) the lighting procedure can be repeated.

NOTE: A safety latching device prevents the knob from being turned to "Ready to ignition", until the thermocouple has cooled down sufficiently, to de-energize the power unit after which the knob will be effective again.

Setting temperature

- To increase setting temperature, turn thermostat knob counter-clockwise towards or over the symbol. To decrease, thermostat knob should be turned clockwise towards the beginning of the symbol.
- Set the thermostat knob at the middle of the symbol for at least two hours, to determine the best setting for the appliance. After that, increase or decrease room temperature, when this will be necessary.

ADJUSTMENTS AND FINAL CHECKOUT

IMPORTANT

*Adjustments must be made by qualified persons only.
Before adjustments can be made the cover should be removed.
If the appliance manufacturer supplies checkout and/or service and maintenance instructions, carefully follow them. If these instructions are not provided then use the procedure outlined below.*

Removing cover (see fig. 1.)

- Unscrew the cover screw at the side of the thermostat knob.
- Put a small screw driver in the slotted hole at the side of the operation knob and lift the cover.

Pilot flame adjustment

Non electric valve is shipped with pilot flow at maximum. Refer to the pilot burner manufacturer's instruction for recommended size of pilot flame. If adjustment is required, turn the pilot adjustment screw clockwise to decrease or counter-clockwise to increase pilot flame.

Outlet pressure adjustment (pressure regulated), see page 8 and page 9

- Check input to the appliance using a clocking gas meter or alternatively a pressure gauge connected to the outlet pressure tap.
- Remove cover to expose pressure regulator adjustment screw.
- Slowly turn adjustment screw with a small screw driver until the required burner pressure is recorded on the pressure gauge. Turn adjustment screw clockwise to increase or counter-clockwise to decrease gas pressure to main burner.
- Replace cover.

For LPG applications the regulator has to be blocked by turning the adjustment screw completely downwards.

Adjustment minimum bypass flow (see page 8)

By turning the adjustment screw anti clockwise, the bypass flow will increase. Turning the screw clockwise, the bypass flow will decrease.

Final checkout of the installation

After any adjustment, set appliance in operation. Observe several complete cycles to ensure that all burner components function correctly.

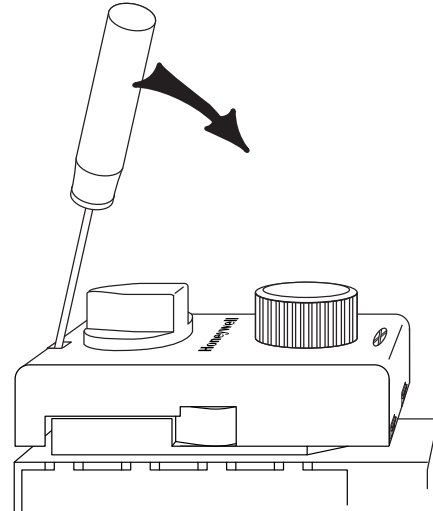

Fig. 1. Removing cover

TROUBLE SHOOTING

NOTE: If the current required is not generated by the pilot burner/thermocouple combination, the thermo-electric safety circuit cuts off the gas supply to the main burner.

If the pilot burner does not light

Possible causes are:

- Gascock is closed, no gas supply.
- Safety valve is closed, no gas supply.
- Knob has not been depressed.
- Pilot gas tubing still contains air. Purge the tube by depressing the knob for one minute and then attempt to relight the pilot burner.
- Pilot flame is too small. For correct adjustment see Pilot flame adjustment page 12

If the pilot flame extinguishes

- Pilot adjustment is incorrect. For correct adjustment see Pilot flame adjustment page 12
- Thermocouple connection to body/interruptor is not tight enough. Make sure that this connection is clean and dry.
- Thermocouple or power unit is faulty. Check thermo electric thermocouple/power unit circuit.

If the power unit does not function.

- Remove power unit from the gas control.
- Mount clean and dry an original Honeywell power unit.
- Check for leakage and operation.

If piezo does not spark

Remove piezo by lifting and turning the lid of piezo igniter at the side of the AMP tag and replace new one.

CONSTRUCTION AND WORKING PRINCIPLES

Pilotstat safety mechanism

Pilotstat provides manual light up and shut down of gas flow to burner. The pilotstat has a built in safety mechanism which ensures that the safety valve remains close in case of a temporary interruption of gas supply until it is proven that the pilot flame is present to light it.

The pilot safety system consists of a thermo element (thermocouple) and a electric safety device (power unit).

When the knob is turned the flow of pilot gas and main gas can be opened and closed according to the demand.

In ON position both pilot gas and main gas flows; in STAND-BY position only pilot gas flows.

When the pilot gas is shut down, the "interlock" falls in a slot and prevents an immediate restart of the heater. Only after the cooling time of the thermo element (drop out time) the latch can lift out of the slot and ignition of pilot gas can be made. In this way the pilotstat safety system prevents the safety valve from opening.

When the knob is turned on and depressed, pilot gas can flow.

When the knob is turned to the STAND-BY position the piezo igniter is activated and ignites the pilot gas. After a waiting period of about 10 seconds the knob can be pressed and turned to the ON position.

The main gas enters the pressure regulator through the disc valve. An adjustable spring is on the diaphragm which gauges the gas pressure behind the valve disc.

Pressure regulation

By adjusting the spring force by means of an adjustment screw, all necessary output pressure levels for both manufactured as natural gas can be adjusted. For LP gas application the pressure regulator is set fully open by turning the adjustment screw until it blocks.

Temperature controller

A SNAP-ON/PROPORTIONAL temperature thermostat is located behind the pressure regulator. This thermostat is based on a liquid expansion system. It consists of a pipe-shaped temperature sensor and a metal diaphragm which are connected to each other by means of a capillary. In this system, an expansion liquid is hermetically sealed. Any temperature change occurring in the sensor environment is transmitted to the metal diaphragm.

This temperature is thereby compared with the value present by the temperature knob. The respective required position of the two valves (snap-on and proportional valve) is then activated by a snap-action mechanism. During the opening process, the snap-on valve opens first and releases a limited flow of gas from the corresponding orifice depending on the type of gas; if more heat is needed, the proportional valve begins to open, and both gas flows are united at the gas output. When less heat is needed, the process is reversed.

For the working area of main flow and switch temperature see Temperature curve page is 7. This value guarantees that the fluctuation of room temperature will not exceed the limits of comfort. There is an overload safety between the metal diaphragm and the switch for short term temperature peaks. It prevents damage to the metal diaphragm in case of increased temperatures.

Pilot gas

The pilot gas is conveyed through the disc valve first in the pilot gas filter. The pilot gas filter removes even the finer dirt from the gas and protects the pilot gas drossel from plugging. The quantity of pilot gas can be constantly adjusted through the gas drossel.

Safety function

Depending on the position of the knob and the position of the power unit, the following situations arise:

I. Burning Position

- Power unit on
Main gas and pilot gas are opened by the safety valve and the disc valve.
- Power unit off
Main gas and pilot gas are closed only by the disc valve. An extra external stop prevents the knob from being pressed, and thus from releasing main gas.

II. Stand-by position

- Power unit on
Main gas is closed by the disc valve but the pilot gas is released.
- Power unit off
Main gas is closed by the disc valve and the safety valve. The pilot gas is closed only by the safety valve.

When the knob is pressed, only the pilot gas is released; when the knob is released, the safety valve closes again.

III. Off position

- Power unit on
The heater is switched off, if the main gas and the pilot gas are closed by the disc valve. Until the thermocouple has cooled down, the safety valve remains open. During this time the "interlock", which falls in a slot when the device is switched off, prevents the knob from being turned and thus from starting up the heater.
- Power unit off
Main gas and pilot gas are closed by both the disc valve and the safety valve. The power unit has lifted the "interlock" from the slot, so that the heater can be started up again.

The closing of the safety valve in case of interrupted gas supply is ensured in any intermediate position of the knob. The combined functions of the knob and the piezo igniter ensures that ignition is possible only when the main gas is closed.

ORDERING INFORMATION

When ordering specify:

- Model number of Non electric valve required: see model number chart.
- Inlet and outlet connection required
- The correct pilot burner for the installation concerned: refer to Honeywell ignition products guide ENOR-0038.
- Order numbers of replacement parts and accessories required, see replacement parts/accessoires.

Order from:

- Your nearest Honeywell branch office.
- Your local Honeywell agent or wholesaler.

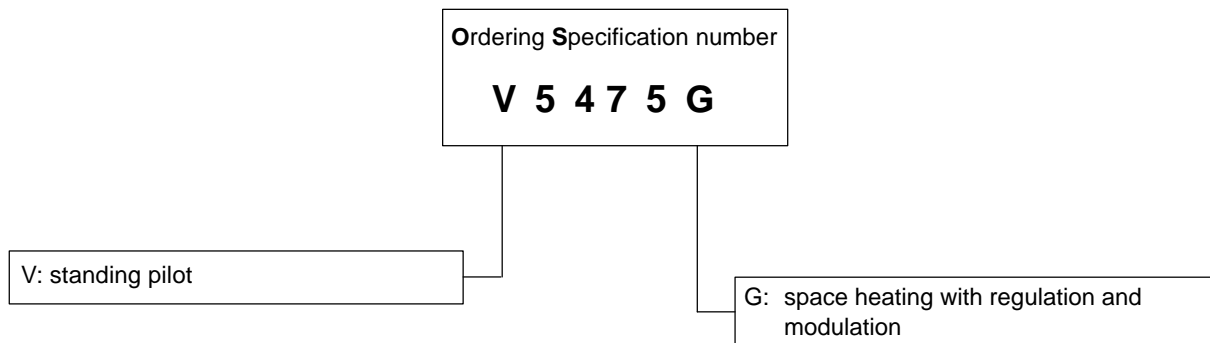

REPLACEMENT PARTS AND ACCESSORIES



WARNING

Take care that only qualified persons carry out the installation of parts, accessories, and add on components. Follow the installation instructions included in the package.

Check that the selected part, accessory or add on component is the correct one for the application in question. Specification of data is given in the instruction leaflet in the package.

Replace the old gaskets with the new ones supplied in the package and check for leakage when the supply is switched on again.

If installation and/or replacement has been completed, a gas leak test must be carried out.

Also check the gas control for satisfactory operation after fitting accessories.

Replacement parts

Description	Packing quantity	Order number
Cover + Screw	100	45.900.401 - 054B
Compression fitting for 6 mm Ø pilot gas tubing	200	45.900.402 - 020B
Gland for gas connection with 4 mm Ø tubing	200	45.900.402 - 014B
Ferrule for gas connection with 4 mm Ø tubing	200	45.900.402 - 015B
Gland for gas connection with 12 mm Ø tubing	200	45.900.402 - 013B
Ferrule for gas connection with 12 mm Ø tubing	200	45.900.402 - 016B
Gland for gas connection with 10 mm Ø tubing	200	45.900.402 - 021B
Ferrule for gas connection with 10 mm Ø tubing		
Thermocouple for Q385A with 600 mm length and 60 s drop out time	100	Q309A 3281B
Thermocouple for Q385A with 750 mm length and 30 s drop out time	100	Q335A 1031B
ECO connector	200	45.900.404 - 006B
Sealing plug in and outlet + O-ring	200	45.900.402-043B
Ignition cable	200	45.900.411-002B

Honeywell

Manufactured for and on behalf of the Environmental and Combustion Controls Division of Honeywell Sàrl, Switzerland by its Authorized Representative:

Automation and Control Solutions

Combustion Controls Europe

Honeywell BV

Phileas Foggstraat 7

7821 AJ Emmen

The Netherlands

Tel.: +31 (-)591 695911

Fax: +31 (-) 591 695200